

Genesis: The Book of Beginnings

Focus	Four Great Events								Four Great Persons				
Divisions	1	2	3	4	5	9	10	11	12	25:19	27	37:2b	50
	Creation		Fall		Flood		Nations (Babel)		Abraham	Isaac	Jacob	Joseph	
Topics	Primeval History of Humanity								Patriarchal History of Israel				
	Beginning of the Human Race								Beginning of the Hebrew Race				
Locations	East (Eden to Ur)								West (Canaan to Egypt)				
Time	2,000 + years (20% of Genesis)								About 286 years (80% of Genesis)				

Author: Moses
Date written: after 1445 BC
Theme: Israel's Origin & Early Years

Purposes: 1) to present the beginning of everything but God
 2) to record God's choice of Israel & His covenant plan for the nation
 3) to show how the sin of man is met by the redemption of God

Genesis 6-9 The Worldwide Flood

6:1-8 The Wickedness of Men

The Date (v1): when men began to multiply & daughters were born to them

The Deed (v2): the sons of God saw that the daughters of men were beautiful & they took wives for themselves whomever they chose.

The Denouncement (v3): the LORD said, "My Spirit shall not **strive** (mg. **Or rule in; some ancient versions read abide in**) with men forever; because he also is flesh; nevertheless his days shall be 120 years.

The Depravity (v4-5a): **The Nephilim** were on the earth in those days, & also afterward (s. Num 13:33), when the sons of God came in to the daughters of men, & they bore *children* to them. Those were **the mighty men** (*Gibborim*) who were of old, men of renown (men of name).

Sons of God, **B nê hæ'elohîm**, occurs only in Job 1:6; 2:1; 38:7; Psalm 29:1; 89:6; Jude 6-7; 2Peter 2:4

The Extent (v5b): every intent of the thoughts of his heart was only evil continually

The Sorrow (v6): The Lord was sorry & grieved in His heart

The Judgment (v7): I will blot out man, animals, creeping things & birds

The Exception (v8): Noah found favor

6:9-9:29 The Generations of Noah

6:9-10 The Righteousness of Noah

6:11-12 The Corruption of the Earth

6:13 The Judgment on the Earth

6:14-22 Noah Instructed to Build an Ark

7:1-5 The Last Seven Days

7:6-12 The Day the Flood Came

7:12-24 The Worldwide Flood

8:1-12 The Waters Subside

8:13-19 The Command to Leave the Ark

8:20-22 The Noahic Covenant

9:1-7 New Instructions Given

The Seven Precepts of Noah (compare Acts 15:19-20)

1. abstinence from blood

2. murder punishable by death

3. the civil authority

4. abstinence from blasphemy

5. abstinence from incest & unchastity

6. abstinence from theft

7. abstinence from idolatry

9:8-17 The Sign of the Noahic Covenant

9:18-19 The Survivors Named

9:20-27 The Curse on Canaan

9:28-29 Noah died

<http://www.gty.org/resources.php?section=transcripts&aid=231779> - edited

“Waves of Judgment” (Genesis 7)

Chapter 7 is the great judgment of all judgments in the history of the world. It is the historical record of God’s destruction of the entire earth and all its inhabitants except those in the ark.

There are several lessons that we can learn from the flood, especially about God: (1) God is not primarily concerned with environmentalism. We can’t even fathom the energy, wisdom, and power that it took to create the original universe and the original earth. 1656 years it was created, God destroyed it all, and out of that flood came essentially a “new” earth and a “new” humanity and a “new” animal plant life. As magnificent as God’s creation is, as reflective of His glory as it is, He would not hesitate to completely destroy it because of sin and bring forth a new earth.

Righteousness and the spiritual world is God’s concern, not the physical. He destroyed the earth once and remade it and He’ll do it again in the book of Revelation. So the Bible begins and ends with the destruction of the earth. In Revelation the earth is first of all renovated and then totally destroyed along with the heavens as we know them and in their place the new heaven and earth which is the eternal state will be created.

<http://www.gty.org/resources.php?section=transcripts&aid=231779> - edited

(2) God has absolute, divine, supernatural power over creation and He has complete freedom to act on it as He wills. God also has complete control of history and everything in it.

(3) God clearly can and does distinguish between the righteous and the unrighteous. So God is not at a loss to know who belongs to Him and who does not.

(4) We also learn from the flood that God is patient, that God is gracious and that God warns sinners of judgment before He brings that judgment. But when that judgment comes we also learn that God judges sin severely.

This judgment of the flood is the most massive and comprehensive judgment of God that has occurred in history and it gives us an understanding of the greater one yet to come when our Lord Jesus returns. But that's not the only judgment. There are judgments going on all the time as God expressed with His anger and His wrath on sinners (**see Romans 1:18**). But when you look at the flood you do learn that God can judge in awesome wrath and fury and anger.

<http://www.gty.org/resources.php?section=transcripts&aid=231779> - edited

Alan Ross writes, **“Such a judgment protects every succeeding word of grace from any kind of innocuousness. God’s gracious redemption is meaningful in the light of that judgment.”** If you can really comprehend that God destroyed the billions of people and saved only eight people, then you know He’s not kidding when He talks about judgment because there’s a record of Him having done it. And every tender warning and every word of mercy and every expression of compassion and every act of grace within the framework of God’s patience is not to be treated lightly or trivialized.

(5) We also learn that God is most concerned about sin. What concerns God is sin in His universe, sin in His world. And so, God sentenced this planet to a short life, basically 6,000 years and then the Millennium before the final destruction and the creation of the new heavens and new earth.

Our “disposable” has been sentenced to a very short life. It is a brief theater in the midst of eternity on which the drama of redemption is played out for the purpose that God might display His grace and His glory and gain a bride for His Son. But God did not hesitate to destroy it in a flash when, in His mind, iniquity is full. God will not always tolerate sinners as He said to the pre-flood world, **“My Spirit will not always strive with man.”**

<http://www.gty.org/resources.php?section=transcripts&aid=231779> - edited

God will not always be patient, not always be tolerant and when judgment comes, it is harsh, it is swift, it is total, and the verdict is incontestable. There is no court of appeals. He did it once and He will do it again. But until that happens, we live in a time of grace.

Genesis 7 is a historical narrative and 120 years have passed since God had said to Noah. **“The end of all flesh has come before me. The earth is filled with violence because of them. Behold, I’m about to destroy them with the earth” (Gen 6:13).** Noah had spent this time building the ark and provisioning it. This was the period of grace that God gave to the pre-flood world, 120 years to repent, while **“the patience of God kept waiting in the days of Noah during the construction of the ark” (1 Peter 3:20).**

The reason for the flood is sin: not only were men involved with demons, his wickedness was so great **“that every intent of the thoughts of his heart was only evil continually” (Gen 6:5).** All that time Noah was absolutely obedient. He was simply told by God that God was going to drown the entire world. He never quibbled about it, he never answered God with queries and questions and misgivings and doubts; he just did **“according all that God had commanded him” (Gen 6:22),** building and preaching of righteousness **(2 Peter 2:5).**

The Generations of Adam (Genesis 5)

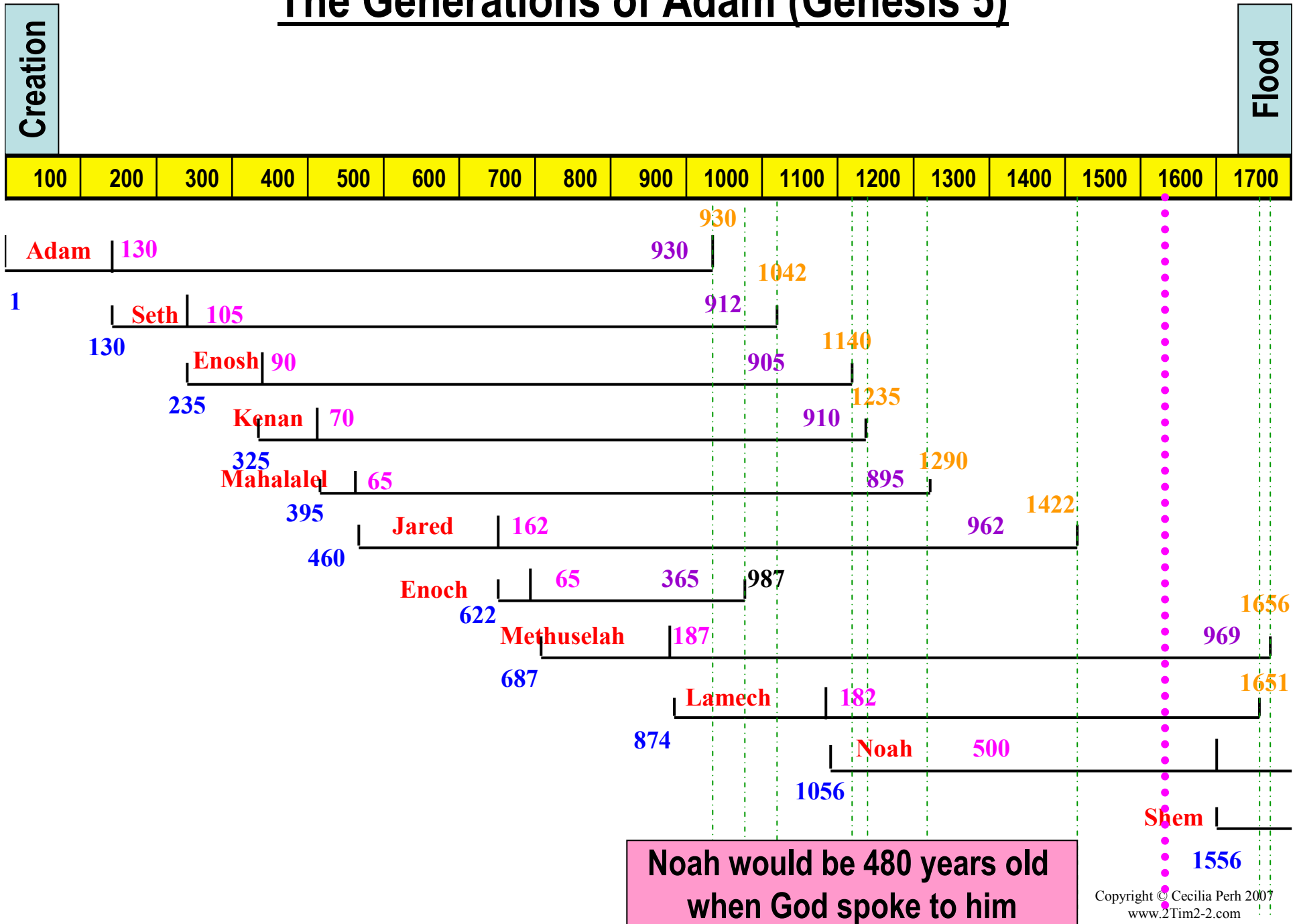

Waves of Judgment (Genesis 7)

The Flood

When asked why he was building this huge, gopher wood ark in the middle of land since there's no ocean here, he might have said, "It's going to rain". Remember, rain had not yet fallen on the earth, but "a mist used to rise from the earth and water the whole surface of the ground" (Gen 2:6). They had never seen rain before and they would have laughed at him.

There is a principle here that you must see, the principle of faith, as Hebrews 11:6 says, "And without faith it is impossible to please *Him*, for he who comes to God must believe that He is, and *that* He is a rewarder of those who seek Him."

Adam was told "in the day you eat from it you shall surely die" (Gen 2:17). Adam and Eve had never seen death before. They had to believe God and His word concerning death. The pre-flood world has never seen rain before, they also had to believe God and His word through Noah concerning "rain" and that the only way of escape was the ark

In our world today, we are told about heaven and hell. We have never seen either, and we must believe God and His word concerning heaven and hell and believe that the only way of escape from God's wrath is through faith in Christ's work on Calvary.

Waves of Judgment (Genesis 7)

The Flood

Well, nobody believed Noah's testimony, and after 120 years the ark was completed, grandfather Methuselah had died and they probably mourned his death for some days and the mourning has just ended.

The Bible gives us patterns that we must learn from so that we have an understanding of the issues that we grapple with in our own lifetimes. An understanding of what is happening in Noah's day is more crucial to us because of what our Lord said:

Luke 17:26-27

“And just as it happened in the days of Noah,
so it shall be also in the days of the Son of Man:
they were eating, they were drinking,
they were marrying, they were being given in marriage,
until the day that Noah entered the ark,
and the flood came and destroyed them all.”

LIFE AS USUAL

Implications

- * the Lord's coming spells judgment or salvation for all
- * the Lord's coming is sudden, unexpected, catastrophic, universal

The Days of Noah

Matthew 24:37-39

Genesis 6:1-13

37 For the coming of the Son of Man will be just like the days of Noah.

38 For

as in those days before the flood
they were eating and drinking,
marrying and giving in marriage,
UNTIL THE DAY that Noah entered the ark,

LIFE AS USUAL

39 and aor act ind, ginosko, to know (of partial experiential knowledge)
they did not understand

UNTIL THE FLOOD CAME aor act ind, erchomai, to come

and TOOK THEM ALL AWAY,

so shall the coming of the Son of Man be. aor act ind, airo, to take up

Implications

- * the Lord's coming spells judgment or salvation for all
- * the Lord's coming is sudden, unexpected, catastrophic, universal

Genesis 7 – The Flood

- 7:1 Then the LORD said to Noah, "Enter the ark, you and all your household; for you alone I have seen to be righteous before Me in this time.
- 7:2 "You shall take with you of every clean animal by sevens, a male and his female; and of the animals that are not clean two, a male and his female;
- 7:3 also of the birds of the sky, by sevens, male and female, to keep offspring alive on the face of all the earth.
- 7:4 "For after seven more days, I will send rain on the earth forty days and forty nights; and I will blot out from the face of the land every living thing that I have made."

The Days of Noah

Did Noah know the exact day the flood will come?

(Genesis 6:1-13)

Did Noah tell them the exact day the flood will come?

Was there a group of people who knew the exact day the flood will come?

What did they do with this knowledge?

LIFE AS USUAL

What will it be like in the days prior to the coming of our Lord?

entered the ark,
(essential knowledge)

they did not understand

UNTIL THE FLOOD CAME

aor act ind, *erchomai*, to come

and **TOOK THEM ALL AWAY**,

so shall the coming of the Son of Man be.

aor act ind, *airo*, to take up

Implications

- * the Lord's coming spells judgment or salvation for all
- * the Lord's coming is sudden, unexpected, catastrophic, universal

Genesis 7 – The Flood

7:5 And Noah did according to all that the LORD had commanded him.

7:6 Now Noah was six hundred years old when the flood of water came upon the earth.

7:7 Then Noah and his sons and his wife and his sons' wives with him entered the ark because of the water of the flood.

7:8 Of clean animals and animals that are not clean and birds and everything that creeps on the ground,

7:9 there went into the ark to Noah by twos, male and female, as God had commanded Noah.



<http://www.genesisfiles.com/Images/elfred3.jpg>

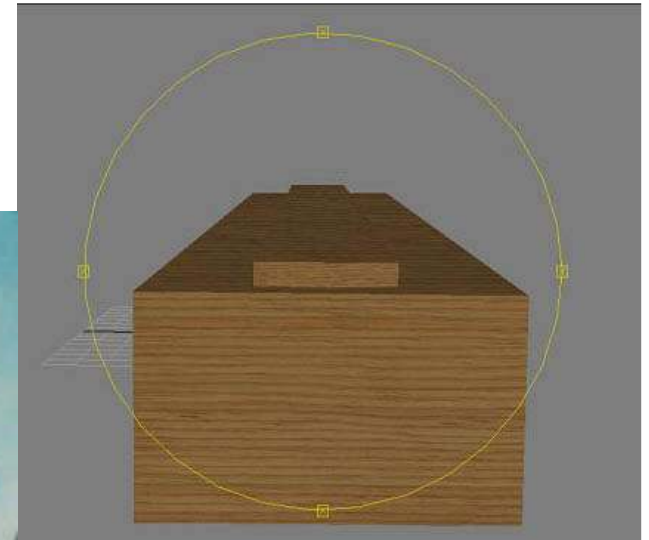

Zero Degree Roll

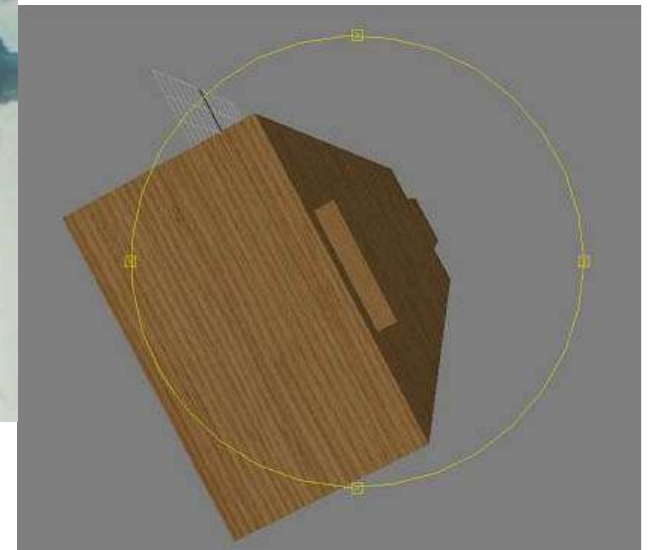

Sixty Degree Roll

<http://www.genesisfiles.com/Images/elfred3.jpg>

- The ark has the same cargo capacity of a modern cargo ship. The above figure shows a comparison with a 550 ft long cargo ship. The ark had a volume of 1.4 million cubic feet and a gross tonnage of 14,000 tons. This is the equivalent of 522 railroad box cars. **The ark could have carried over 125,000 sheep-sized animals.** Interestingly, there are less than 18,000 species of land animals alive today. Also, the average size of most animals is less than that of a sheep.

Stability

- A scale model of the ark was tested in a special tank at Scripps Institute of Oceanography at La Jolla, California. The tank was capable of generating giant waves with respect to the model boat, thus simulating severe sea conditions. The waves were much larger than would be experienced in the ocean. **The ark proved impossible to capsize. Due to the rectangular shape, it proved capable of righting itself, even to 90 degrees.** This is unheard of on an ocean-going vessel. Most vessels will develop severe stability problems at more than a 60 degree list. **The Ratio of the ark is 30 x 5 x 3. It turns out that this design is a perfect design to prevent capsizing in rough seas.**

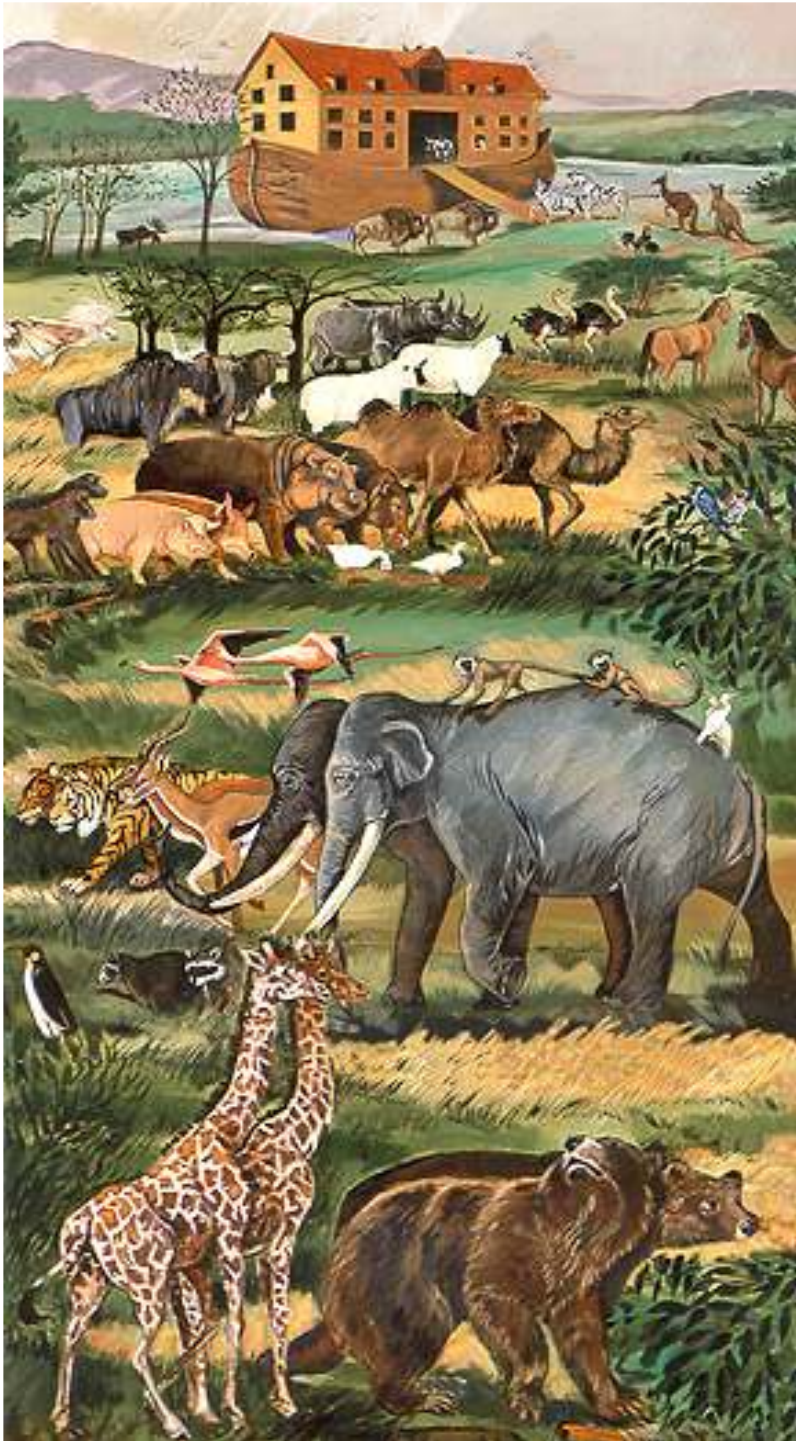

<http://www.gty.org/resources.php?section=transcripts&aid=231779> - edited

In **Genesis 6:19**, God told Noah to take two of every kind of all flesh into the ark to keep them alive, male and female. Here God clarifies and gives fresh information, **“Take with you of every clean animal by sevens,”** (**Gen 7:2**) - here’s the first mention of clean animals in scripture.

Remember, Genesis was written for the Hebrews who have just come out of Egypt and in the Torah, particularly Leviticus 11 dealing with clean and unclean animals which has to do with sacrifices and dietary laws. All of those things existed before the Mosaic Law was given. There was already sacrifice (**Gen 4**) and Noah will offer sacrifices using the clean animals once he came out of the ark (**Gen 9**). So sacrifices and offerings already existed and Noah and the righteous ones must have known which animals are clean and which are unclean.

The dietary laws concerning what they can eat (the clean) and what they can’t eat (the unclean) were really to teach separation. This is not new. From the Garden of Eden with its two trees - one allowed, one forbidden - to the eternal destiny of man being either in heaven or in hell, the Bible sets forth two and only two ways: God’s way and every other way.

<http://www.gty.org/resources.php?section=transcripts&aid=231779> - edited

People are either saved or lost, they either belong to God or to the devil, there is the narrow way or the broad way, eternal life or destruction, those who're against us and those who are for us, those within and those without, life and death, truth and falsehood, good and bad, light and darkness, the kingdom of God and kingdom of Satan, love and hate, spiritual wisdom and the wisdom of the world. We have to make distinctions and in the early days of God's dealings with men, He wanted them to learn and make those distinctions. This was one major reason for the Mosaic laws.

The reason why Noah took in seven pairs of clean animals, male and female, was for sacrifices. This is clearly seen in **Genesis 8:20**, "Then Noah built an altar to the LORD, and took of every clean animal and of every clean bird and offered burnt offerings on the altar." Remember when they came off the ark, it would take a while for animals to reproduce and they wanted to make sacrifices regularly. By the way none of these animals were for eating since all were vegetarian till after the flood. It's not till **Genesis 9:3-4** that the Lord gives the command for to eat meat.

<http://www.gty.org/resources.php?section=transcripts&aid=231779> - edited

It's interesting that the Babylonians and the Assyrians as a rule brought sacrifices to their deities only of herds and flocks, cattle and sheep, and in very rare instances, of mountain goats. The Babylonians and Assyrians considered dogs and pigs to be unclean, and if they ever offered dogs or pigs, it was not offered to their gods but they were giving gifts to the demons. Or they would sacrifice a dog or a pig to serve as a substitute for a sick person so that the sick person's sickness would go into the dog or the pig. So they were always used in very negative ways. Even the Babylonians and the Assyrians got a little of the spill over of that concept of distinctions.

Genesis 7:3 adds, "And also of the birds of the sky by sevens, male and female." Perhaps at this time, all birds were designated as clean, although later in the Mosaic Law, there were some flying animals that were designated as unclean, mainly because they ate carrion.

Back to **Genesis 7**, it must have been God who brought all the animals to Noah, for he wouldn't be able to know which would be best. Thus the animals which came into the ark would be the most healthy ones and they would have been in the most productive stages of their lives because they would repopulate the post-flood world.

<http://www.gty.org/resources.php?section=transcripts&aid=231779> - edited

All the genetic material is there in just one pair of animals. The whole science of genetics is fascinating. Those genes can be put into varying combinations and various mutations occur and adaptations occur so that all the animals of all the world that have ever been since the flood can come from two of the species.

For a better understanding, think this of Mr and Mrs Noah whose three sons produced everybody from pygmies and dwarfs to seven foot NBA players and Zulus and everybody in between. From Mr and Mrs Noah came all skin colors, all physical characteristics, all body types, all eye shapes, all noses, all eye colors, all hair colors, natural not artificial – and all the genetic coding was in those two people, and the combinations were multiplied by each new union without limit.

To show you how limitless it is, in the scientific journals, scientists have estimated that, in theory, if just two human parents could produce more children than there are atoms in the universe no two would be alike. We all know about that even identical twins do not have the same fingerprints. The variability is absolutely staggering. As they mated, variations began to appear together with some mutations. It is loss of genetic information that we have to contend with.

<http://www.gty.org/resources.php?section=transcripts&aid=231779> - edited

For example, in the case of dogs: what happens if you have a short haired dog and a long haired dog and they wandered up to Siberia? In a few hundred years, you'll only find long haired dogs there. Why? Because dogs with no hair or short hair died. That's adaptation and an explanation for the varieties of dogs today. It's loss of genetic information that causes the mutation, which means that every succeeding generation becomes "worse" as time goes on.

Also, when you go to the hotter parts of the world where, as a general rule, people have darker skin. Why? Because darker skinned people thrive better while pale skinned people were contracting melanomas, skin cancers and things like that and tended to diminish.

All this variety operates out of this one gene pool. From Adam first and then again in Noah plus defective genes causing mutations and creating racial characteristics. These racial characteristics - skin color, features, eye shape - is 6% of that 0.2 variation or 0.012, which is trivial. We are all one race of man, we are one big family of mankind that God has created.

Acts 17:26 says, "and He made from one, every nation of mankind to live on all the face of the earth, having determined *their* appointed times, and the boundaries of their habitation".

<http://www.gty.org/resources.php?section=transcripts&aid=231779> - edited

So it was enough to have two of anything on the ark that would supply all the necessary genetic material to populate the earth with everything that's ever lived here in the animal kingdom as well as the human world. 4500 years have gone by and the curse has also been operating and through that curse there has been mutations and adaptations. Certain amount of genetic information has been lost so that disease has developed and deformity in the genes causes much of it. No process can add new information and there's no real recovery possible. Humanity has been declining in its function and form. We probably aren't close at all to what Mr and Mrs Noah and their family were like or even Adam and Eve. One thing for sure, we didn't live as long! But there was everything necessary in that representation of life on the ark to populate the entire planet again.

Genesis 7 – The Flood

- 7:10 And it came about **after the seven days**, that the water of the flood came upon the earth.
- 7:11 **In the six hundredth year of Noah's life, in the second month, on the seventeenth day of the month, on the same day** all the fountains of the great deep burst open, and the floodgates of the sky were opened.
- 7:12 And the rain fell upon the earth **for forty days and forty nights**.
- 7:13 **On the very same day** Noah and Shem and Ham and Japheth, the sons of Noah, and Noah's wife and the three wives of his sons with them, entered the ark,

Genesis 7 – The Flood

7:14 they and every beast after its kind, and all the cattle after their kind, and every creeping thing that creeps on the earth after its kind, and every bird after its kind, all sorts of birds.

7:15 **So** they went into the ark to Noah, by twos of all flesh in which was the breath of life.

7:16 And those that entered, male and female of all flesh, entered as **God** had commanded him; and the **LORD** closed *it* behind him.

<http://www.gty.org/resources.php?section=transcripts&aid=231779> - edited

Then God sent rain and “**all the fountains of the great deep burst open, and the floodgates of the sky were opened**” (verse 11). So God’s pristine perfect world was shattered, the crust of the earth was cracked (perhaps this was when our tectonic plates was formed), letting loose on the surface of the earth all the reservoir of water that up till this point had watered the earth. This cataclysmic convulsion sends the water in the air and creates the deluge that essentially drowns the earth in 40 days and 40 nights.

The word “rain” (**Gen 7:4**), *matar*, refer to normal rain, but it came for 40 days and 40 nights and by the time you get down to **verse 12**, the word “rain” is *geshem*, a torrent, because after 40 days and 40 nights what starts out as rain becomes a deluge, a torrential downpour (see also 1 Kings 18:45; Ezekiel 13:11,13).

Now such a rain covering the entire earth would be impossible under our current climatological conditions and since the universal flood. There’s not enough water in the water canopy surrounding our earth. One scientist figured out that today, if all the water in the atmospheric heaven above us and all the water around the earth was dropped on the earth, it would be less than an inch deep when it covered the earth.

[http://en.wikipedia.org/wiki/Vapor_canopy# Pre-Flood_atmospheric_conditions](http://en.wikipedia.org/wiki/Vapor_canopy#Pre-Flood_atmospheric_conditions)

Where then did all that water come from?

There are several opinions held by creationists:

- 1. The vapor canopy theory states that before the Great Flood the earth was surrounded by a "canopy" of water in either liquid, solid, or gas form, and that the water from the canopy contributed greatly to the flood waters. The earliest water canopy proposal was that of Isaac Vail in 1874, but the idea came to prominence in 1961 with the publication of the book *The Genesis Flood* by Henry Morris and John Whitcomb.**

Creationists are no longer agreed on the merits of the idea; for instance, Walt Brown's Center for Scientific Creation opposes it. It has also fallen into disfavor at *Answers in Genesis*[1], which now advocates the catastrophic plate tectonics model for the Flood. One major proponent is Kent Hovind.

<http://www.thetruthishere.com/canopy.html>

A Water Canopy?

- **Genesis 1:6-7 "And God said, Let there be a firmament in the midst of the waters, and let it divide the waters from the waters. And God made the firmament, and divided the waters which were under the firmament from the waters which were above the firmament: and it was so. And God called the firmament Heaven."**
- **These illustrations show just how a water canopy covering the Earth would not only create a globally warm climate but also would shield our planet from harmful radiation. Thus, allowing mankind to reach ages up to 900 plus years and also allowing reptiles to grow to the size of our dinosaur fossils. A global flood that occurred roughly 1,500 years after Adam was created would create the coal layers (compressed global vegetation) and the fossilization of the huge behemoths known to us today as the dinosaurs. Remember, in Genesis 1:6-8, God divided the waters from the waters and placed this upper water canopy ABOVE the firmament called "Heaven."**

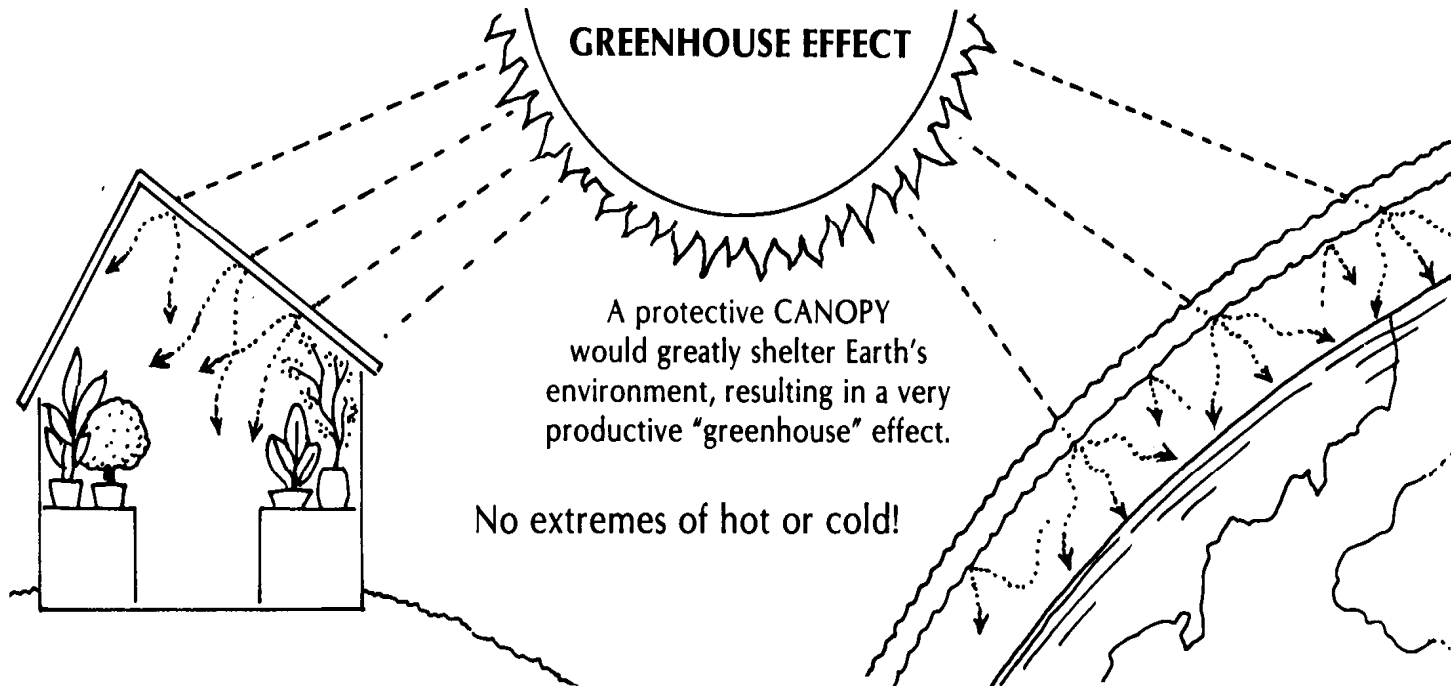

A moderate warm climate prevailing from pole to pole, just like in a greenhouse.

WHAT COULD THE RESULTS BE?

- Possible longer life spans
- Possible larger specimens of some plants and animals.

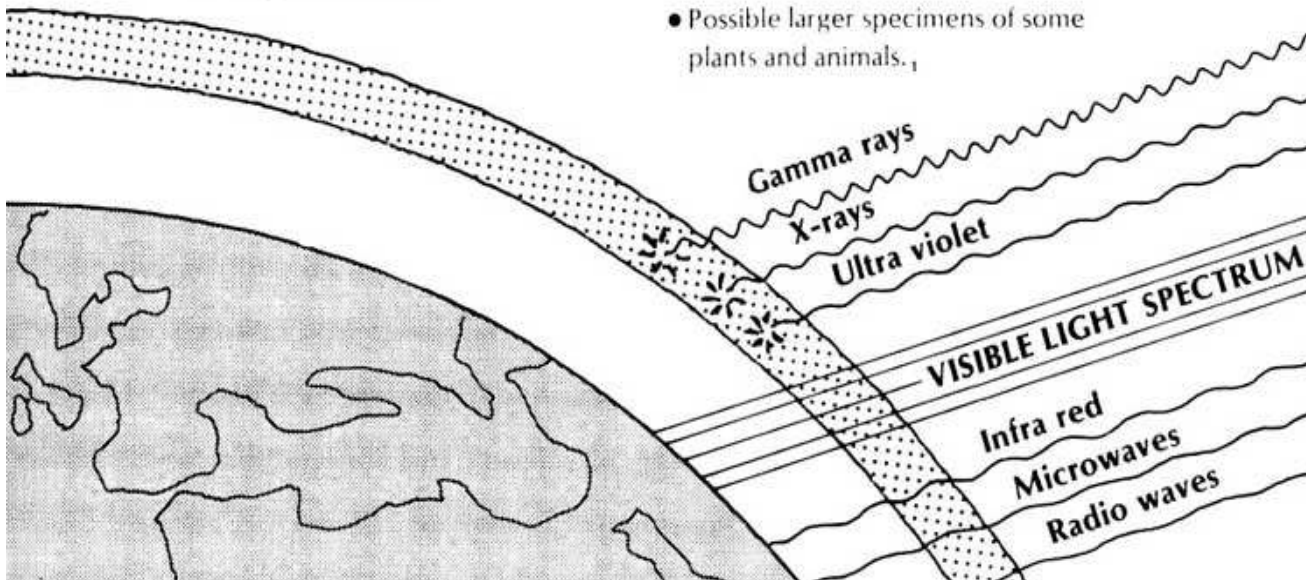

[http://en.wikipedia.org/wiki/Vapor_canopy# Pre-Flood_atmospheric_conditions](http://en.wikipedia.org/wiki/Vapor_canopy#Pre-Flood_atmospheric_conditions)

- 2. Catastrophic plate tectonics is a pseudoscientific theory proposed by creationist John Baumgardner, to explain the biblical global flood. It has received tentative support from creationist organizations such as Answers in Genesis[citation needed].**
- 3. Walt Brown's hydroplate theory - Hydroplates are an alternative hypothesis proposed by retired USAF colonel and mechanical engineer Walt Brown of superfast continental drift in his book titled, In the Beginning: Compelling Evidence for Creation and the Flood. They are not regarded by the scientific community to be founded on science. Many creationist organizations such as Answers in Genesis and the Institute for Creation Research consider the hydroplate notion to be unworkable. Brown proposes that there was once a layer of subterranean water that acted as a lubricant, allowing the continents to rapidly move from their former position to their present-day position in only a few years (or less). Brown claims that a one-mile-thick layer of salt water has been detected 10 miles below the Tibetan Plateau [1]. This belief is used as support for a biblical inerrantist view of the creation and flood accounts in the Bible.**

[http://en.wikipedia.org/wiki/Vapor_canopy# Pre-Flood_atmospheric_conditions](http://en.wikipedia.org/wiki/Vapor_canopy#Pre-Flood_atmospheric_conditions)

4. **Some creationists believe that the global flood did not solely affect the Earth, but also involved Mars and possibly other planets[1]; however, no scientific mechanism has yet been proposed for such an event.**
- **All these are but theories that some scientists would use to explain the world the way it is today. The Scriptures do not spend any time on the “how” of the flood. It is more concerned with the “why” of the flood. And we should learn from this to be less concerned about trying to figure out the geology, hydrology, the geophysical or biological effects, or its impact on radiation, which effects carbon 14 dating or oceanic nitrogen, etc, Rather than getting all wound up in that, the Lord would have you more concerned about the impact that sin has on human life. That’s the message that you and I must heed. Science will keep on changing and evolving as we learn more, and what is laughed at today may be proved to be true tomorrow. Our convictions should be based solely on truths of Scripture and not on the changing winds of science.**

BREAK TIME

Genesis 7 – The Flood

- 7:17  Then the flood came upon the earth for **forty days**; and the water increased and lifted up the ark, **so that** it rose above the earth.
- 7:18 And the water prevailed and increased greatly upon the earth; and the ark floated on the surface of the water.
- 7:19 And the water prevailed more and more upon the earth, **so that** all the high mountains everywhere under the heavens were covered.
- 7:20 The water prevailed fifteen cubits higher, and the mountains were covered.

Genesis 7 – The Flood

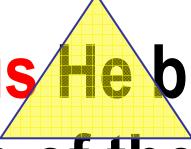
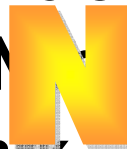
- 7:21 And all flesh that moved on the earth perished, birds and cattle and beasts and every swarming thing that swarms upon the earth, and all mankind;
- 7:22 of all that was on the dry land, all in whose nostrils was the breath of the spirit of life, died.
- 7:23 **Thus**  **He** blotted out every living thing that was upon the face of the land, from man to animals to creeping things and to birds of the sky, and they were blotted out from the earth; and only  **N** was left, together with those that were with him in the ark.
- 7:24 And the water prevailed upon the earth **one hundred and fifty days.**

<http://www.gty.org/resources.php?section=transcripts&aid=231778>

Was this a Local Flood or a Universal Flood?

There are over 270 different nations, races, and tribes that have in their tradition a flood story. The Babylonians have a flood story called Gilgamesh Epic. So do some the Athapascan Indians on America's West Coast, the Papago Indians of Arizona, the Algonquin Indians of Northeast United States, the Brazilian tribes, also in Papua New Guinea, the Mexicans, the natives of Alaska, the Hottentots in South West Africa, the Greenlanders, natives of Hawaii, the Welsh, the Lithuanians. Flood traditions exist in the history of India, China and Egypt. That's just a sampling of 270 different people groups that have a flood story in their tradition. Obviously, these flood stories are garbled to some extent from the original Biblical account because of their cultural idiosyncrasies and their false religions.

Some statistics to help us:

- 88% of the 270 flood narratives say that there was, in the midst of the flood, a favored family that was spared.
- 70% say that survival was by means of a boat.
- 95% say that the sole cause of this great catastrophe that came on the whole world was a flood.

<http://www.gty.org/resources.php?section=transcripts&aid=231778>

- 66% percent say that it came because of man's wickedness.
- 67% say that animals also were saved.
- 57% say that the survivors ended up on a mountain.
- Many of them use some form of Noah's name, like the Hawaiian legend about Nu'u...
- Many of them speak about birds being sent out, a rainbow, and that eight people were saved.

This shouldn't surprise us because they had a common ancestor, one of the sons of Noah.

Hugh Miller, a careful investigator of these stories way back in the 1800s, wrote, “The destruction of well nigh the whole human race in an early age of the world's history by a great deluge appears to have so impressed the minds of the few survivors and seems to have been handed down to their children in consequence with such terror struck impressiveness that their remote descendents of the present day have not even yet forgotten it. It appears in almost every mythology and lives in the most distant countries and among the most barbarous tribes.”

<http://www.gty.org/resources.php?section=transcripts&aid=231778>

The Scriptures testify that it was a universal flood, not a local one

- 1) the extensive language in [Genesis 6-9](#). Repeatedly, it says that the whole world was covered, that the mountains were covered, that all under heaven perished.**
- 2) the construction and outfitting and populating of the ark was an absurdity if the flood was local.**
- 3) after the flood, God promised never again to destroy the world as He had done ([Gen 8:21](#)).**
- 4) Genesis traces all the people in the world back to Noah and his family.**
- 5) other Biblical references to the flood affirm its universality ([Psalm 104:5-9](#); [2 Peter 3: 5-7](#); etc).**

<http://www.gty.org/resources.php?section=transcripts&aid=231778>

The flood was the second massive catastrophic event in the history of the world. The first was the creation of the universe in six 24-hour days by God out of nothing. And the universe was created mature, full-grown, with no process. Creation lasted six days. The flood lasted a year and a month. Creation gave us the first earth. The flood gave us the second earth, the earth that we know and experience and which is constantly and slowly winding down as when new toys become old and worn out.

These two events explain our world, and only the Bible gives an accurate record of these two events because it was God who gave this account to Moses.

Thus for Christians, the starting point for understanding our world is Scripture...accurately interpreted. The Bible is the starting point for the true understanding of every subject it addresses and every area of truth that matters. The true understanding of Creation is found in the opening chapters of Genesis. The true understanding of a worldwide flood is not to be found by studying the Babylonian Gilgamesh Epic or by studying some tribal legend. The true understanding of the flood, as well as the true understanding of Creation, is to be gained by understanding the Bible.

<http://www.gty.org/resources.php?section=transcripts&aid=231778>

If you are a Christian, you may be excused for your ignorance of astrophysics, geology, microbiology, genetics, or any other area of science. But you will not be excused for willful ignorance of God's Word.

Our Lord Jesus said, "Have you not read?" to the critics of His day, the religious leaders. He said to them, in **Matthew 22:29**, "**You're mistaken, not understanding the Scriptures, or the power of God.**" That's the real problem even today.

We learn from the flood that (1) God has absolute freedom and power over His creation. He made it in six days, and He can destroy it in 40.

(2) God hates sin. He is intolerant of it and He judges it with a furious anger.

(3) God's judgment spares no guilty soul. God literally destroyed the whole of humanity with the exception of eight people. He is totally impartial when He judges sin.

(4) God's grace and salvation have profound meaning in light of God's judgment. There is no escape from God's judgment except by the means that He ordains.

<http://www.gty.org/resources.php?section=transcripts&aid=231778>

As the water prevailed more and more upon the earth, the ark would begin to rise and float. All humanity and all of the animal world was reduced to what's in that little box bobbing on the top of the waters. The waters rose until all "the mountains everywhere under the heavens were covered" and it kept on rising until it was at least fifteen cubits (at least 22½ feet) higher than the tops of the highest mountains then. The mountains prior to the flood were no doubt lower, maybe hills more than mountains. Today, we have mountains as high as nearly 30,000 feet. The flood wouldn't have enough water to cover those, but they rose out of the flood as God, during that time, was reshaping the planet.

The Mount St. Helens explosion back in 1980: The steam explosion released energy equivalent to 20 millions tons of TNT when that mountain blew its lid. It toppled 150 square miles of forest in six minutes. Spirit Lake nearby, north of the volcano, created an enormous tidal wave from the tremendous explosion, and it stripped slopes of trees 850 feet above the lake's level. Total energy output was equivalent to 40 million tons of TNT from that one mountain, 20,000 Hiroshima A-bombs. And that's just one volcano.

<http://www.olywa.net/radu/valerie/StHelens.html>



May 17, 1980 Harry Glicken, USGS



<http://www.gty.org/resources.php?section=transcripts&aid=231778>

When God broke up the planet and reshaped it, it would be that multiplied almost an infinite number of times. The face of the land was changed by steam blasts, landslides, water waves, hot pumice ash, mud floes, etc. Six hundred feet of strata was formed in a handful of minutes. Wherever you find strata, you cannot explain strata by time adding it on one layer at a time which adds up to the millions of years that are being propounded today. It doesn't happen that way.

Strata is a result, and there are tests after tests after tests to prove this. Strata is created by a force moving, and it piles up several layers, then it rolls over and keeps on piling and rolling over, so that you may have the latest life on the bottom layer, rather than on the top.

This is a study in itself and there are many articles on the Internet that you can read to see what happened to the geological strata in the flood. Visit Pompeii and see the unbelievable devastation that was caused by Mount Vesuvius, another volcano. The eruption of Krakatau changed the surface of the earth.

http://www.geology.sdsu.edu/how_volcanoes_work/Krakatau.html



Early in the morning of May 20, 1883, the captain of the German warship *Elizabeth* reported seeing an ~11-km-high cloud of ash and dust rising above the uninhabited island of Krakatau, thus documenting the first eruption from this Indonesian island in at least two centuries. Over the ensuing two months, crews on commercial vessels and sightseers on chartered ships would experience similar spectacles, all of which were associated with explosive noises and churning clouds of black to incandescent ash and pumice. From a distance, the largest of these natural fanfares impressed the local inhabitants on the coastal plains of Java and Sumatra, creating a near-festive environment. Little did they realize, however, that these awe-inspiring displays were only a prelude to one of the largest eruptions in historic times. A series of cataclysmic explosions began at mid-day on August 26, and ended on August 27 with a stupendous paroxysmal eruption. On this day, the northern two-thirds of the island collapsed beneath the sea, generating a series of devastating pyroclastic flows and immense tsunamis that ravaged adjacent coastlines. The events that began on August 26 would mark the last 24 hours on earth for over 36,000 people, and the destruction of hundreds of coastal villages and towns.

http://www.geology.sdsu.edu/how_volcanoes_work/Krakatau.html



Indonesia contains over 130 active volcanoes, more than any other country on earth. They comprise the axis of the Indonesian island arc system, which is generated by northeastward subduction of the Indo-Australian plate. The great majority of these volcanoes lie along the topographic crest of the arc's two largest islands - Java and Sumatra. to generate highly explosive eruptions.

The islands are separated by the **Sunda Straits**, which is located at a distinct bend in axis of the island arc volcanoes, from a nearly east-west orientation in Java to a northwest-southeast orientation in Sumatra. Krakatau is one of a several volcanic islands in the Sunda Straits located above an active north-northeast trending fault zone, an orientation quite distinct from the main island-arc trend. Although relatively small when compared to the largest volcanoes along the island arc, Krakatau and its associated volcanoes have shown the capacity to generate highly explosive eruptions.

http://www.geology.sdsu.edu/how_volcanoes_work/Krakatau.html

The pre-eruption island of Krakatau was composed of three coalesced volcanoes aligned along a north-northwest direction, parallel to the volcanoes on Sumatra. From north to south, these were Perboewatan, Danan, and Rakata.



During the eruption, Perboewatan, Danan, and the northern half of Rakata appear to have collapsed into the vacating magma chamber, thus forming a submarine caldera and destroying the northern two-thirds of the island. Some workers, however, have argued for an alternative to the caldrion-collapse model, and instead have suggested that the caldera formed by explosive destruction of the island, and the reaming out of the pre-eruption edifice. Eruptions since 1927 have built a new cone called *Anak Krakatau* ("child of Krakatau") in the center of the 1883 caldera.

<http://www.gty.org/resources.php?section=transcripts&aid=231778>

The Bible doesn't give us any idea of the tremendous disturbance that occurred in Genesis. But [Psalm 104:5-9](#) does:

- 5 “He established the earth upon its foundations,
So that it will not totter forever and ever.
- 6 Thou didst cover it with the deep as with a garment;
The waters were standing above the mountains.
- 7 At Thy rebuke they fled;
At the sound of Thy thunder they hurried away.
- 8 The mountains rose; the valleys sank down
To the place which Thou didst establish for them.”
- 9 Thou didst set a boundary that they may not pass over;
That they may not return to cover the earth.

The flood comes. As God begins to dissipate the flood, He pushed up the mountains and drops down the great ocean basins, and filled those basins with the ocean and put a limit or a shore so that they could go no further beyond to inundate the world.

<http://www.gty.org/resources.php?section=transcripts&aid=231778>

There was nothing alive except some fish. Most fish were killed, but some survived and those who were in the ark, the people and the animals and birds. What were the conversations were like among those eight people. It would be 2½ after the 150 days before the water had receded enough to see a mountain, before God had pushed a mountain up. It would be another 4½ months before the dove could find dry land, and almost 8 months before they could leave the ark. In total, a year and a month on the boat before they could step out to find out what was left of their world. Essentially there was nothing left of the world they had known. It was a completely new world.

The holocaust of the flood answers the fossil record. It explains the stratification, the extinction of all air-breathing life and the massive destruction of marine life because of the tremendous movement of the crust of the earth that was under water, and because of the tremendous cataclysms that were going on. There was massive mud moving and stratification which, of course, buried marine life as well as life on land. And so we have evidence of that massive, massive death and trapping of marine life, as well as land animals.

<http://www.gty.org/resources.php?section=transcripts&aid=231778>

We learn from the flood that the Lord is not interested in geology. **Genesis 7:21-22**, “And all flesh that moved on the earth perished, birds and cattle and beasts and every swarming thing that swarms upon the earth, and all mankind; of all that was on the dry land, all in whose nostrils was the breath of the spirit of life, died.”

God is interested in theology and the flood is to teach us the future of sinners, which is devastating. They all died in a holocaust of judgment. Note that there is no note of sympathy here because the decision is without regret on the part of God and without remedy. Sinners and their corrupted environment must be destroyed. It happened once, and it will happen again. The wicked will be destroyed by fire that will incinerate the entire universe (see **2 Peter 3:7**). The day of grace has gone and now the day of judgment has come and it is without mercy.

Verse 23 says, “Thus He blotted out every living thing that was upon the face of the land, from man to animals to creeping things and to birds of the sky, and they were blotted out from the earth; and only Noah was left, together with those that were with him in the ark.” God takes full responsibility for all the destruction. This is not a natural disaster. This is a supernatural judgment. God did this.

<http://www.gty.org/resources.php?section=transcripts&aid=231778>

Deuteronomy 32:39

- “See now that I, I am He, And there is no god besides Me; It is I who put to death and give life. I have wounded, and it is I who heal; And there is no one who can deliver from My hand.”

Ezekiel 33:29

- “Then they will know that I am the Lord, when I make the land a desolation and a waste because of all their abominations which they have committed.”

Psalm 34:16

“The face of the Lord is against evildoers
To cut off the memory of them from the earth.”

- God is never reluctant to take full responsibility for judgment on sinners. He ascribes that judgment to Himself. This may bother some of you but that is the way it is. You can choose to rail against God or you can choose to take His way of escape. Regardless of your choice, know that the day of God’s judgment will fall on the entire world when Christ Jesus returns.



Post-Flood
CATASTROPHISM

Genesis 8:1-5 – God Remembers Noah

- 8:1 **But** God remembered Noah and all the beasts and all the cattle that were with him in the ark; and God caused a wind to pass over the earth, and the water subsided.
- 8:2 Also the fountains of the deep and the floodgates of the sky were closed, and the rain from the sky was restrained;
- 8:3 and the water receded steadily from the earth, and **at the end of one hundred and fifty days** the water decreased.
- 8:4 And **in the seventh month, on the seventeenth day of the month**, the ark rested upon the mountains of Ararat.
- 8:5 And the water decreased steadily **until the tenth month; in the tenth month, on the first day of the month**, the tops of the mountains became visible.

<http://www.gty.org/resources.php?section=transcripts&aid=231778>

The lesson here for us is the lesson of judgment but also of grace found **Genesis 8:1**, “**But God remembered Noah.**” God has perfect recall of who belongs to Him and He knows what we need.

Zakar, “remember”, is used with God as the subject 73 times and what’s interesting is that it is most often followed by the preposition “TO”, i.e., God remembered to... indicating that God’s remembering is an action taken on behalf of somebody. God remembered Noah, i.e., God remembered to provide a protection for Noah. God remembered him through the flood. They were drifting with no control, clueless as to where they were, enduring only on the promise of God. No escape was possible. They could never go out for a walk. And the longer they were in the ark, the more aware of their own sinfulness they would be day by day, and they probably were more aware of God’s amazing grace.

God also remembered “**all the beasts and all the cattle that were with him in the ark, and God caused a wind to pass over the earth and the water subsided.**” Man needed the animals because they would provide food and service for man. So God caused a wind, “*ruach*”, same word as the Spirit in **Genesis 1:2**.

<http://www.gty.org/resources.php?section=transcripts&aid=231778>

It's probably true that there hadn't been wind in the past. There was a whole different hydrology because there was a different environment. There wasn't the kind of wind that we know today, because there wasn't the kind of cloud movement that is necessary to life on the planet with evaporation of the water into the clouds and the clouds moving over the land to redeposit to provide for man. So God sent wind, strong winds that would begin to move the waters, assisting and aiding in the evaporation, which could now occur more rapidly since the sun was fully exposed, the canopy being removed. God must have sent a hot wind to pass over the earth to aid in the subsiding of the water.

But it was still 2½ months before the tops of the mountains were visible and 4½ months before they could find any land, and over a year before they could leave the ark. But God remembered.

The rain had stopped. The subterranean caverns had collapsed and the surface elevations had changed correspondingly, and the water was beginning to flow down the hills and the mountains into the valleys, into rivers, and into the deep caverns that became the beds of the seas.

<http://www.gty.org/resources.php?section=transcripts&aid=231778>

All of this was stupendous in power and creativity. God created mountain ranges which tower up to 30,000 feet. He created ocean depths. There are some parts of the sea in the Pacific that are as low as 35,000 feet in depth. God reshaped the earth, and He restrained the water below and the water above. **“The water receded steadily from the earth, and at the end of a hundred and fifty days it decreased. And in the seventh month, on the seventeenth day of the month, the ark rested on the mountains of Ararat” (Gen 8:3-4).**

What was the calendar at that time? It seems that the month was 30 days long, and that they could have had a 360-day year, which implies that the earth rotated a lot quicker, probably because its shape may be rounder than it is today. Our earth today is tilted at 23.45° .

There is a Mount Ararat which is 17,000 feet high. But the ark rested on the mountains of Ararat, NOT on Mt Ararat. The ancient name is *Urarto*, in what is today Armenia, southeast Turkey.

Genesis 8:6-12 – The Waters Dry Up

- 8:6 **Then** it came about **at the end of forty days**, that Noah opened the window of the ark which he had made;
- 8:7 and he sent out a raven, and it flew here and there **until** the water was dried up from the earth.
- 8:8 **Then** he sent out a dove from him, to see **if** the water was abated from the face of the land;
- 8:9 **but** the dove found no resting place for the sole of her foot, **so** she returned to him into the ark; **for** the water was on the surface of all the earth. **Then** he put out his hand and took her, and brought her into the ark to himself.

Genesis 8:6-12 – The Waters Dry Up

8:10 **So** he waited **yet another seven days**; and **again** he sent out the dove from the ark.

8:11 And the dove came to him **toward evening**; **and behold**, in her beak was a freshly picked olive leaf. **So** Noah knew that the water was abated from the earth.

8:12 **Then** he waited **yet another seven days**, and sent out the dove; **but** she did not return to him **again**.

<http://www.gty.org/resources.php?section=transcripts&aid=231777>

•God's Miraculous Restoration of Mankind (Genesis 8:6-22)

With the earth completely submerged in water, there were massive mudslides and movements of sediment. Sedimentary rock was formed in the holocaust of the flood and it was literally being pushed and accumulated all over the face of the earth.

So in the first part of the flood, sedimentary rock was on the surface of the earth at many points. Then, in the latter half of the flood, God begins to push the mountains up with volcanic movement and as the mountains push up, they also push up the sedimentary rock so that you find the sedimentary rock on the top of mountains. That is why in almost every mountain range on the face of the earth, you find marine fossils at the top of the mountain because there were in the sedimentary rock before it was pushed up. In the Himalayas, for example, they find fossilized sea animals above 18,000 feet.

The highest parts of the mountain ranges are often limestone which is rock formed by the gradual deposit on the seabed of shells. When you find limestone at the top of a mountain, you know that it once was at the bottom of the sea. That's another indication that the whole face of the earth was changed dramatically in the flood.

<http://www.gty.org/resources.php?section=transcripts&aid=231777>

There are volcanic mountains on the floor of the ocean, many of them litter the ocean floor of the Pacific, which are sort of residual volcanoes, which had collapsed into the great ocean basins.

So when the flood began to subside, God began to fracture more the surface of the earth and push up the mountains. Then the water began to disappear as it began to roll down the sides of the hill and collect in the rivers which then flowed into the ocean basins, which are at the lowest point of the earth.

So when Noah and his family stepped out of the ark, they saw a very different world. There were massive mountains and great valleys which had not been there before. And there was death everywhere.

A question that was asked was “Why aren’t there lots of fossils of men?” The answer is that when the flood came, men built boats and they keep floating as long as they could float; some would run to the highest places, or climb trees to escape the flood. Therefore, they weren’t necessarily buried. Obviously some of them have been discovered buried in stratification and fossils. Their carcasses would have been exposed to the sun and the water and would disintegrate.

<http://www.gty.org/resources.php?section=transcripts&aid=231777>

But when Noah and his family came out, they probably saw the bones of dead people and dead animals all over the place, decomposing in the sun. Many other bones, of course, were deposited and buried in the sediment.

So when they walked into a post-flood world, the first thing they were extremely aware of was divine judgment. They would have literally gasped at what they saw. For the most part, plants had been destroyed; the coal beds in the belly of the earth are from fossilized plant material.

There wasn't a north pole and a south pole before, for they had the same moderate climate all around. That's why you find leaf-eating mammoths instantly destroyed on the edge of the Arctic circle, where a leaf-eating creature couldn't live today.

There was some vegetation, some seeds starting to sprout life, and some trees that no doubt survived because they had roots which can survive in water and not a lot of ground. But they would have seen a devastated earth –stark, indescribable evidence of God's judgment on sin.

<http://www.gty.org/resources.php?section=transcripts&aid=231777>

Noah first sent a raven and today we know it was a scavenger bird which would eat just about anything. The raven never came back and perhaps the reason was because it could perch on dead bodies or floating trees and eat decaying flesh. In the Mosaic Law, the raven was considered unclean and was unfit for food or for sacrifice (**Leviticus 11:15, Deuteronomy 14:14**).

Then he sent out a dove, a very docile bird, easily tamed which only ate vegetation. Doves were birds of the valley, according to the old rabbis, and they needed to find a settled place in a valley or a place on a low cliff, just above the ground. They would make their little nest in a low cliff, so they could fly out of that low cliff and get the vegetation that was in the valley. The dove was a clean bird, according to the **Leviticus 11:15** and **Deuteronomy 14:14**. The dove was the symbol of gentleness and later on in the Old Testament, a symbol of beauty. It was used for sacrifice and could be eaten.

The raven wouldn't tell Noah whether the water was gone. It could only tell him there was death out there. But the dove would tell him there was life out there, because the dove would have to find a plant to eat. And all the animals on this ark had to have some plants to eat. Remember, nothing at this point was carnivorous.

<http://www.gty.org/resources.php?section=transcripts&aid=231777>

But the dove returned because it could find no resting place for the sole of her foot. The dove is a nester and needed to roost. It also couldn't find anything to eat so it returned.

Noah then waited another seven days to send that dove out. It returned with a freshly picked olive leaf.

One interesting thing about the olive tree is that it can survive under water for a long time. In fact, olive trees are hearty trees and they have so much oil in them, that when you cut a branch and want to carve it, you have to let it sit for a very long time, or it remains green and very difficult to carve. And even after you've carved it, it's liable to split and not give the effect that the carver wants. So it takes a long time to dry out, even a cut branch and that fits the Biblical account very well.

The raven showed Noah there was death. The dove showed Noah there was life, a freshly picked or plucked olive leaf. That meant the little hills were exposed, the land was being dried, and the valleys were becoming clear. So Noah knew the water was abated from the earth.

Genesis 8:13-19 – Leaving the Ark

8:13 Now it came about **in the six hundred and first year, in the first month, on the first of the month**, the water was dried up from the earth.  Then Noah removed the covering of the ark, and looked, **and behold**, the surface of the ground was dried up.

8:14 And **in the second month, on the twenty-seventh day of the month**, the earth was dry.

8:15  Then  God spoke to Noah, saying,

8:16 "Go out of the ark, you and your wife and your sons and your sons' wives with you."

Genesis 8:13-19 – Leaving the Ark

8:17 "Bring out with you every living thing of all flesh that is with you, birds and animals and every creeping thing that creeps on the earth, that they may breed abundantly on the earth, and be fruitful and multiply on the earth."

8:18 **So** **N**oah went out, and his sons and his wife and his sons' wives with him.

8:19 Every beast, every creeping thing, and every bird, everything that moves on the earth, went out by their families from the ark.

Genesis 8:20-22

God's Response to Noah's Worship

8:20 Then Noah built an altar to the LORD, and took of every clean animal and of every clean bird and offered burnt offerings on the altar.

8:21 And the LORD smelled the soothing aroma; and the LORD said to Himself, "I will never again curse the ground on account of man, for the intent of man's heart is evil from his youth; and I will never again destroy every living thing, as I have done.

<http://www.gty.org/resources.php?section=transcripts&aid=231777>

Verse 13 gives us the day the earth was dried up: in the 601st year, in the first month, on the first of the month. These dates are given to remind us that this is History, not fantasy or myth or not allegory.

“Then Noah removed the covering of the ark, and looked and behold, the surface of the ground was dried up.” It was dried up. But Noah still waited inside the ark until God told him to leave.

He steps out at the command of God and his job was to repopulate the earth, along with the animals. It's like a preview of what will happen after Armageddon.

The land that had once teemed with animals and people and vegetation has been replaced by an incredibly desolate wilderness. The air, which formerly was warm and gentle, now moved in stiff, cold and sometimes violent winds. And there was a chill on the mountain slopes of Ararat where the ark was resting and dark clouds rolled across the sky, which had once been pleasantly bright. It seemed to threaten more rain and the recurrence of flood conditions.

The earth had been purged of the wicked humanity that had made its physical beauty a mockery, and that was good. But what was left was bleak, barren and foreboding.

ICE AGE



- Warm ocean/cold continents
- Much evaporation
- Many volcanoes, dust in atmosphere, great air movements because of temperature differential
- Much precipitation: snowfall in northern atmosphere
- Snow packed down into ice and spread out as a large continental glacier
- Probably lasted between time of Noah and Abraham

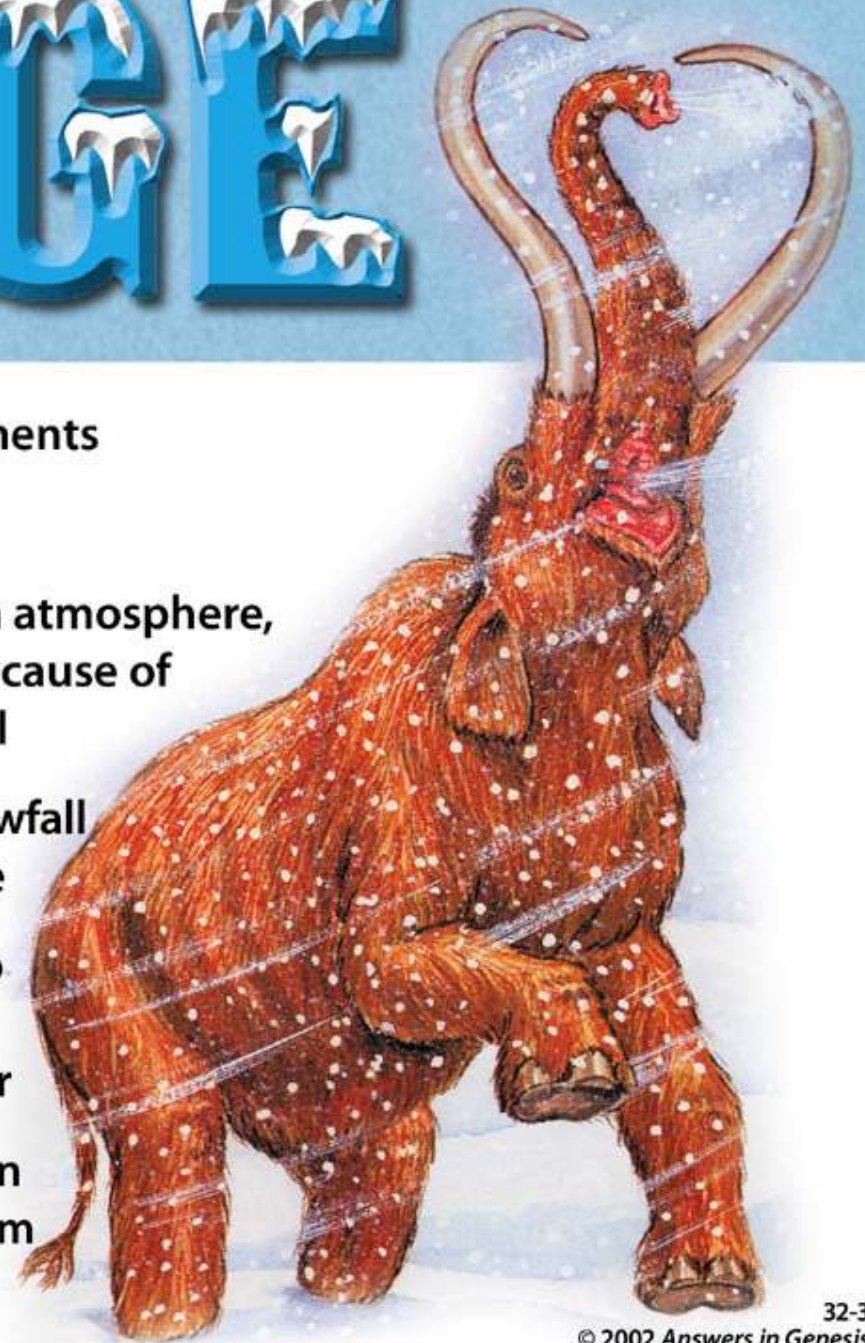

<http://www.gty.org/resources.php?section=transcripts&aid=231777>

Dr. Henry Morris says “There were, no doubt, physical changes along the lines of these. The oceans were much more extensive, since they are now contained all the waters, which once were above the firmament in the subterranean reservoirs of the deep. The land areas were much less extensive than before the flood, with a much greater portion of the surface of the earth uninhabitable for this reason. The thermal vapor blanket was dissipated, so that strong temperature differentials were inaugurated, leading to a gradual buildup of snow and ice on the polar latitudes, rendering much of the extreme northern and southern land surfaces also essentially uninhabitable. Mountain ranges uplifted after the flood emphasized the more rugged topography of the postdiluvian continents, with many of these regions also becoming unfit for human habitation. Winds, storms, rains, snow were possible now, thus rendering the total environment less congenial to man and animals than it had been before. The environment was also more hostile because of harmful radiation from space, no longer filtered out by the vapor canopy. A gradual reduction in human longevity after the flood. Tremendous glaciers, rivers, and lakes existed for a time, with the world only gradually approaching its present state of semi-aridity. And that is what is known as the Ice Age. The Ice Age occurring after the flood.”

<http://www.gty.org/resources.php?section=transcripts&aid=231777>

“The crust of the earth was in a state of general instability reflected in recurrent volcanic and seismic activity all over the world which we know very well in southern California and continuing to some degrees even to the present.”

So Noah and his family went out. The animals also walked off the ark “by their families” (verse 19). And the first thing Noah did was to build an altar to the Lord, and to take of every clean animals and every clean bird and offer burnt offerings on the altar (verse 20). A burnt offering was totally consumed, and was symbolic of total devotion and dedication to the Lord. Everything was given to the Lord.

Noah’s gratitude caused him to offer this tremendous sacrifice from EVERY clean animal and bird, because he understood how much he owed the Lord. He was giving of his all to the Lord because he owed God all. But the burnt sacrifice also symbolized Noah’s recognition of his sinfulness and the need of repentance. This is the first mention of an altar used for the purpose of sacrifice in the Bible. Noah knew he was not a perfect man and he understood that it was pure grace that God saved him and his family out of the entire world.

<http://www.gty.org/resources.php?section=transcripts&aid=231777>

When it says, “God smelled the soothing aroma”, We understand that this is an anthropomorphic way of saying God was pleased with the heart of the worshiper. The sacrifice pleased God. In Exodus, Leviticus and Numbers, you will find this same imagery of the Lord smelling the sacrifice, smelling the soothing aroma, and it expresses divine favor. Sometimes, as in **Leviticus 26:31**, God refuses to smell the sacrifice and that means divine disapproval and rejection.

In response to that act of worship, God promised to never destroy the world as He had done, i.e., not via a universal flood.

The flood did not remove fallenness from the world, because Noah and his whole family were fallen, sinful creatures, and they reproduced sinners. Sinners deserve immediate destruction. But God gave us grace and we’re still living in the period of His grace. But the time of judgment is surely coming as the evil of men accumulates and rises up to heaven again.

Man is still depraved, but God pledges to be gracious and patient. Why? **Romans 2:4** says His kindness, forbearance and patience are to lead people to repentance.

Genesis 8:20-22

God's Response to Noah's Worship

8:22 **"While the earth remains,
Seedtime and harvest,
And cold and heat,
And summer and winter,
And day and night
Shall not cease."**



<http://www.enchantedlearning.com/subjects/astronomy/planets/earth/Seasons.shtml>

The Seasons and Axis Tilt

- The Earth's seasons are not caused by the differences in the distance from the Sun throughout the year (these differences are extremely small). The seasons are the result of the tilt of the Earth's axis. The Earth's axis is tilted from perpendicular to the plane of the ecliptic by 23.45° . This tilting is what gives us the four seasons of the year - spring, summer, autumn (fall) and winter. Since the axis is tilted, different parts of the globe are oriented towards the Sun at different times of the year.
- Summer is warmer than winter (in each hemisphere) because the Sun's rays hit the Earth at a more direct angle during summer than during winter and also because the days are much longer than the nights during the summer. During the winter, the Sun's rays hit the Earth at an extreme angle, and the days are very short. These effects are due to the tilt of the Earth's axis.

<http://www.enchantedlearning.com/subjects/astronomy/planets/earth/Seasons.shtml>

Solstices

- The solstices are days when the [Sun](#) reaches its farthest northern and southern declinations. The winter solstice occurs on December 21 or 22 and marks the beginning of winter (this is the shortest day of the year). The summer solstice occurs on June 21 and marks the beginning of summer (this is the longest day of the year).

Equinoxes

- [Equinoxes](#) are days in which day and night are of equal duration. The two yearly equinoxes occur when the [Sun](#) crosses the celestial equator.
- The vernal equinox occurs in late March (this is the beginning of spring in the Northern Hemisphere and the beginning of fall in the Southern Hemisphere); the autumnal equinox occurs in late September (this is the beginning of fall in the Northern Hemisphere and the beginning of spring in the Southern Hemisphere).

The Seasons on Earth

Autumnal Equinox

The first day of Autumn in the Northern Hemisphere

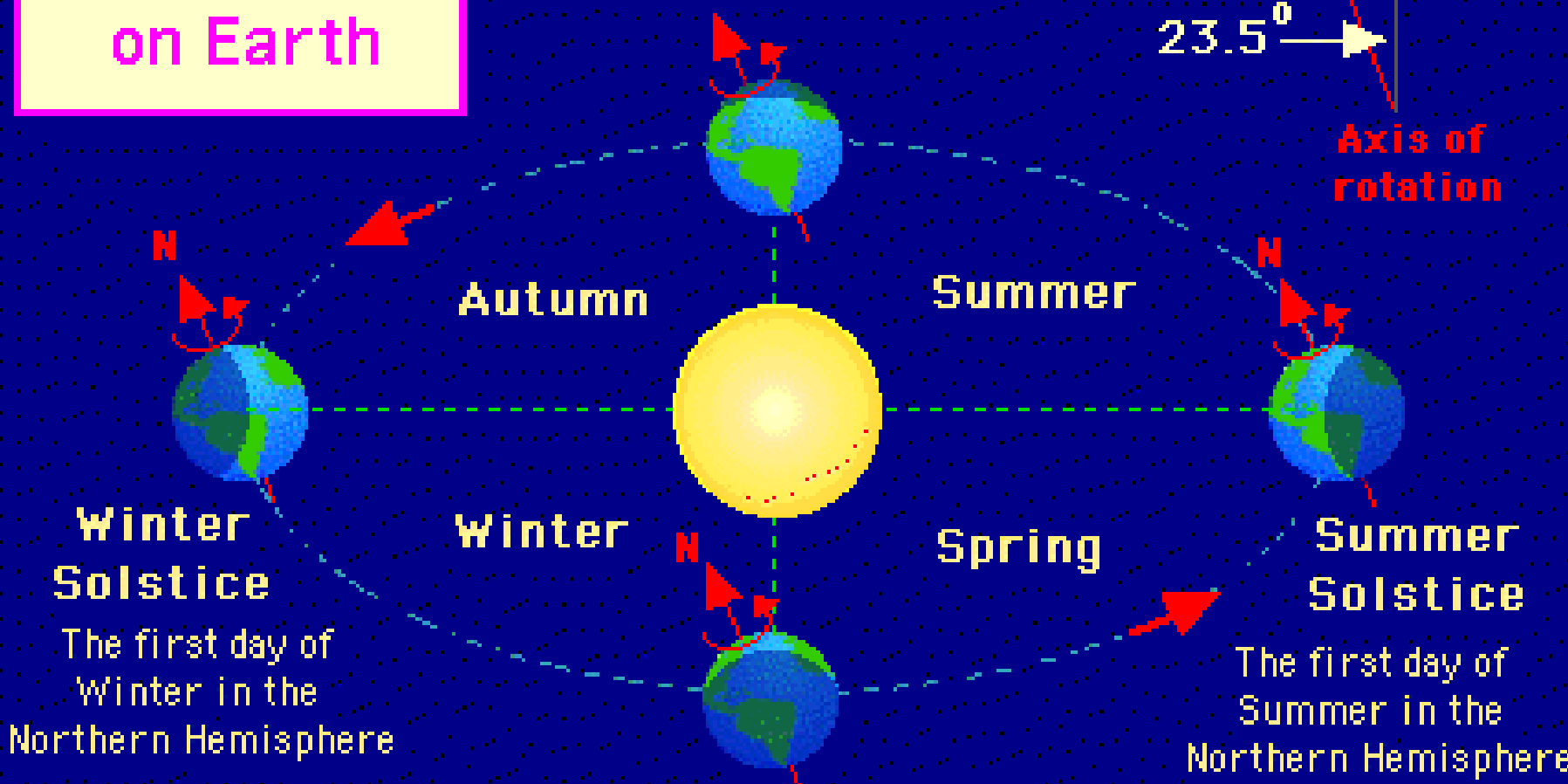
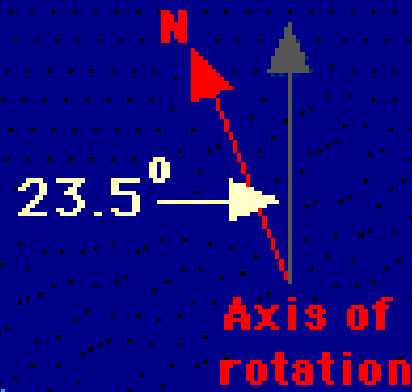

Winter Solstice

The first day of Winter in the Northern Hemisphere

Winter

Spring

Summer Solstice

The first day of Summer in the Northern Hemisphere

Vernal Equinox

The first day of Spring in the Northern Hemisphere

The Sun and the Earth are not to scale in this drawing.

©ZoomSchool.com

<http://www.gty.org/resources.php?section=transcripts&aid=231777>

Why is life the way it is today? Why is it so consistent? Because God has promised it would be. As long as this earth remains and until it goes out of existence, there will be seedtime, harvest, cold, heat, summer, winter, day, night – predictable, regular cycles. There will be a consistent pattern of the motion of heavenly bodies, consistent gravity, consistent rotation of the earth, consistent solar orbit, and consistent annual cycles. The earth will not be blasted into smithereens by a meteor. It will not fly out of orbit. We will not all die from global warming. It'll always be regular routine, cold in the winter, warm in the summer, and there will be seedtime and harvest, that's spring and fall. And there will be day and night, and this will never change, as long as the planet is here.

But one day, the cup of iniquity is full, the judgment of God will fall and the Lord Jesus Christ will return. And the heaven will open **“and behold, a white horse, and He who sat upon it is called Faithful and True; and in righteousness He judges and wages war? (Rev 19:11).**

2 Peter 3:3-18

3 Know this first of all, that **in the last days** mockers will come with *their* mocking, following after their own lusts, 4 and saying, "Where is the promise of His coming? **For ever since** the fathers fell asleep, all continues **just as** it was from the beginning of creation." 5 **For when** they maintain this, it escapes their notice that by the word of God *the* heavens existed long ago and *the* earth was formed out of water and by water, 6 through which the world **at that time** was destroyed, being flooded with water.

7 **But** the present heavens and earth by His word are being reserved for fire, kept for the day of judgment and destruction of ungodly men. 8 **But** do not let this one *fact* escape your notice, beloved, that with the Lord **one day is as a thousand years, and a thousand years as one day.** 9 The Lord is not slow about His promise, as some count slowness, **but** is patient toward you, not wishing for any to perish but for all to come to repentance. 10 **But** the day of the Lord will come like a thief, in which the heavens will pass away with a roar and the elements will be destroyed with intense heat, and the earth and its works will be burned up.

2 Peter 3:3-18

11 **Since** all these things are to be destroyed in this way, what sort of people ought you to be in holy conduct and godliness, 12 looking for and hastening the coming of the day of God, on account of which the heavens will be destroyed by burning, and the elements will melt with intense heat! 13 **But** according to His promise we are looking for new heavens and a new earth, in which righteousness dwells.

14 **Therefore**, beloved, **since** you look for these things, be diligent to be found by Him in peace, spotless and blameless, 15 and regard the patience of our Lord to be salvation; **just as** also our beloved brother Paul, according to the wisdom given him, wrote to you, 16 **as** also in all *his* letters, speaking in them of these things, in which are some things hard to understand, which the untaught and unstable distort, **as they do** also the rest of the Scriptures, to their own destruction.

17 You **therefore**, beloved, knowing this beforehand, be on your guard lest, being carried away by the error of unprincipled men, you fall from your own steadfastness, 18 **but** grow in the grace and knowledge of our Lord and Savior Jesus Christ. To Him be the glory, **both now and to the day of eternity**. Amen.



Life Magazine, Sept. 5, 1960

While Paul walked along rugged slopes he saw the shape of a boatlike vessel on a mountain side near Mount Ararat, Turkey. The boatlike form of a long vessel may have guided him up the mountain slope. The shape, he said, had the outline of a great cargo ship.

NOAH'S ARK?

Boatlike form is seen near Ararat

